



POWER SERIES

Premium 550 EC

Category Benefits

This model offers the following benefits:

- Food waste is ground into particles and flushed away
- A convenient solution to food waste in the home
- Lift & Latch Technology makes it easy to install into new or existing kitchens and can be fitted to most sinks

Features

This model offers the following features:

- **0.55 HP induction motor** provides maximum grinding power and durability
- **Reduced sound**
- **Advanced Grind** for tough and fibrous food scraps
- **2-Stage MultiGrind Technology.** Finest grind (Compared to 1-Stage MultiGrind Technology)
- **Removable Baffle**
- Safe for use with properly maintained septic tanks
- Air Switch in Chrome

Warranty

Up to 3-Year Limited Warranty*

* Visit www.insinkerator.com/product-registration for warranty details.

Specifications

| | |
|-----------------------------|---|
| Type of Feed | Continuous |
| On/Off Control | Air Switch |
| Motor | Single Phase |
| Motor HP | 0.55 |
| Volts | 220-240 |
| HZ | 50-60 |
| Motor Power, W | 380 W |
| Time Rating | Intermittent |
| Lubrication | Permanently Lubricated Upper & Lower Bearings |
| Shipping Weight (Approx.) | 8.12 kg |
| Overall Height | 31.2 cm |
| Motor Protection | Automatic Reset |
| Drain Connection | 3.8 cm Cushioned Slip Joint |
| Dishwasher Drain Connection | Yes |
| Grind Technology | 2-Stage MultiGrind Technology |
| Plug | Schuko |
| Grind Chamber Capacity | 980 ml |

Dimensions

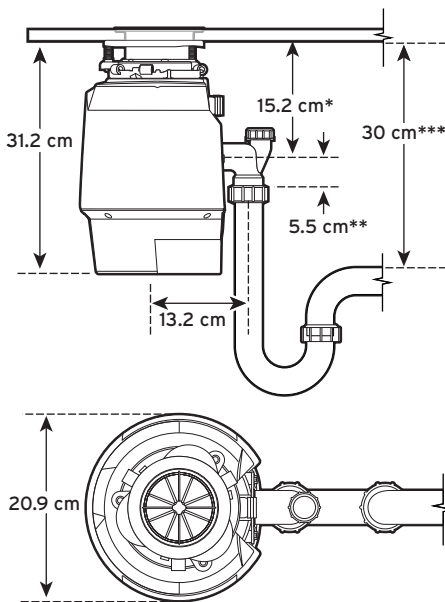

*Distance from bottom of sink to centre line of disposer outlet. Add 12.7 mm when stainless steel sinks are used.

**Length of tailpipe from centre line of disposer outlet to end of tailpipe.

***Distance between bottom of sink bowl to the waste pipe to be minimum of 30 cm.

